

Figure 1 - Slide Bolt Lock Parts

The installation instructions are the basis for Security Agency Approvals. The lock installation must be done in accordance to these instructions in order to maintain the labeled approval level.

In order to maintain VdS Class 2/EN 1300 Class B lock approval levels in a container where multiple locks are required, special considerations must be observed. The Auditcon 2 Series lock must be the first one secured by the boltworks. Check the locked status of the container with the handle of the boltworks.

Design Parameters for Auditcon 2 Series Locks

1. Bolt dimensions (nominal): .312 inches x 1.000 inches/8 x 25.4mm
2. Bolt movement (nominal) : .465 inches/11.8mm
3. Bolt extension:
 - Square Nose Slide Bolt is .465 inches/11.8mm
 - Roller Slide Bolt is .495 inches/12.6mm
4. Maximum load movable by the bolt: None

Note: Auditcon 2 slide bolt locks will not open if force is applied to the end or side of the bolt.

5. Maximum load against bolt when thrown (all directions): 1kN (224.8 lbs.)
6. The lock can be fitted to safes or vault doors of any material.

Note: As is the case with all mechanical and electronic locking devices, the container and boltworks must be designed to protect the lock.

Basic Tools and Materials Needed

- Medium Phillips head screwdriver (#2) (recommend magnetized tip)
- ESD wrist band

Recommended, but not required:

- Torque screwdriver (30 inch-pounds/3.4 newton-meters capacity)
- Loctite® 262 (Red) for use on lock case mounting screws

WARNING: Kaba Mas locks are protected from 25,000 V Electrostatic Discharge (ESD) damage when correctly installed. Follow these precautions to avoid ESD damage when installing the lock:

- Handle the keypad assembly by the outer edge only.
- Use an ESD wrist band grounded to the lock or container during installation.

Prepare for New Installation of the Lock

(If Required)

1. Using the lock parts along with the template provided, establish the exact location for the drilled and tapped holes.

Caution: The lock case must be mounted exactly according to the template if mounted over the cable routing hole. Otherwise, the lock case must be mounted so that no part of the case covers the cable routing hole.

2. The spindle hole diameter can be a minimum of .406" (10.3mm) to a maximum of .438" (11.1mm). The .406" (10.3mm) diameter is recommended. Spindle hole must be deburred.

3. The keypad/base assembly mounting screws require drilled and tapped holes to 3/8" (9.5mm) depth if possible (minimum 1/4" or 6.4mm depth required.) Drill either the two horizontal mounting holes or the two vertical holes.

4. When mounting the lock unit (i.e., integrating it in a boltwork), make sure that the lock bolt has clearance to freely move to its end positions and that the shifting force works only in the axial direction (direction of movement). Lateral forces should not be exerted on the lock. A minimum clearance of 1/16" (1.6mm) is required between the bolt roller/nose and the inside edge of the strike. Refer to Figures 2 and 3.

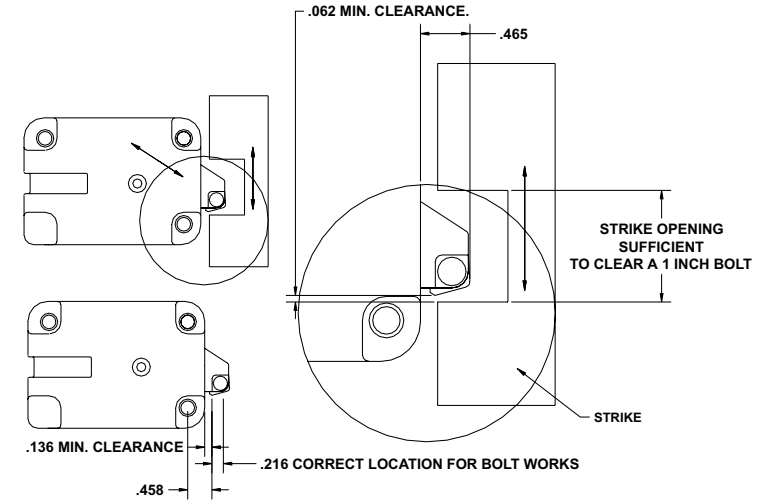

Figure 2 - Square Nose Slide Bolt Clearances and Positioning

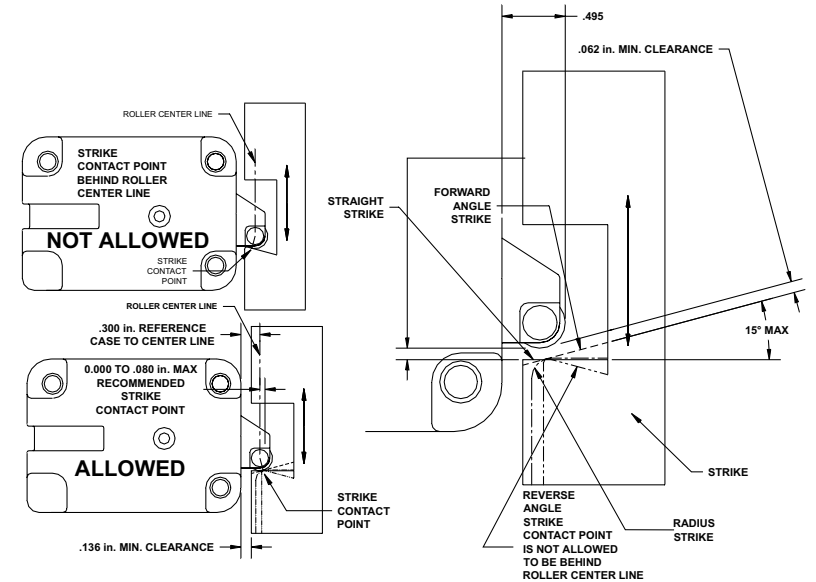
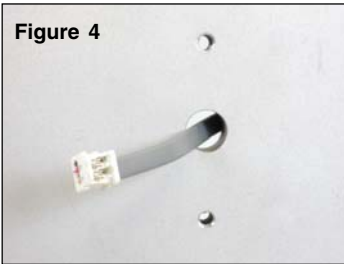

Figure 3 - Roller Slide Bolt Clearances, Strike Types & Contact Points

Part I: Install Front Housing Assembly

1. Route the end of the lock cable with the Picoflex connector from the back of the container door through the cable routing hole. (Figure 4)



2. Remove the front cover from the keypad/base assembly.

3. Hold the keypad/base assembly in the upright position (i.e., the keypad is positioned at the top) and hold the keypad in place. Guide the cable through the cable receiving hole from the back of the keypad/base assembly. (Figure 5)

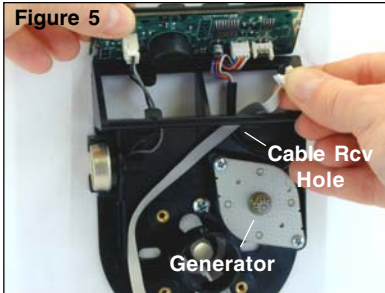

4. Route the lock cable toward the keypad so that the cable will not be pinched by the generator. Gently lift the keypad board assembly and guide the cable up through the cable receiving hole in the keypad/base assembly. (Figure 5)

5. Insert the Picoflex connector on the end of the ribbon cable into the header on the keypad with proper orientation. (Figure 6)

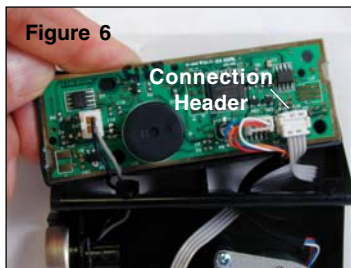

6. Insert the spindle from the back of the keypad/base assembly. (Figure 7)

7. Position the keypad/base assembly firmly against the container door and attach it to the container door using the two #8-32 (or M4-0.7) keypad/base assembly mounting screws. (Figure 8) Do not fully tighten screws.

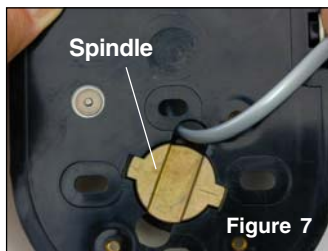

8. Position the cable and the keypad so that they will not be pinched when the front cover is snapped into place.

9. Pull excess cable through to the inside of the container.

10. Tighten the keypad/base assembly mounting screws. (Torque 17-20 lbs., 1.9-2.25 N-M) (Figure 8)



11. Center the front cover over the keypad/base assembly and gently snap into place.

12. Mount the front cover to the keypad/base assembly using the round mounting holes on the cover and the three #6-32 mounting screws. (Torque 14-16 lbs., 1.6-1.8 N-M) (Figure 9)

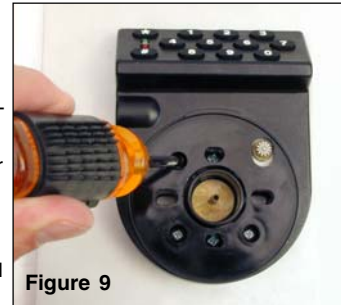

13. Place the nylon dial spacer over the spindle.

14. Place the dial onto the spindle and seat into the dial bushing. Push gently on the dial so that the gear on the generator seats properly into the gear teeth on the dial.

15. Plug the RJ11 end of the cable into the lock case in order to test the lock.

16. Test the operation of the lock before completing the installation of the front cover by verifying the following:

- Ensure that the dial turns freely without scraping.
- Power the lock by turning the dial briskly in any direction until simultaneous green and red flashes display and two beeps sound to indicate the lock is powered. Key in the Factory Combination. (For a Model 52 or T52, enter "502550". For a Model 252 or 552, enter a two-digit number in the range from 01-20, followed by "502550".) If the combination is entered successfully, continuous green flashes display to indicate that the lock is ready to open. Rotate the container handle to unlock. Then rotate the handle back to the locked position.

Note: After correctly entering a valid combination, you must retract the bolt within 4-6 seconds.

17. Unplug the RJ11 end of the cable from the lock case and lay the case aside.

18. After successfully testing lock operation, hold the cover assembly in place and remove the dial.

19. Apply a small amount of lubricant to the gear on the generator, the bearing surface of the dial (the portion that fits into the dial bushing of the base assembly), and the teeth around the edge of the dial.

20. Place the dial onto the spindle and seat into the dial bushing. Push gently on the dial so that the gear on the generator seats properly into the gear teeth on the dial.

21. Insert the #4-40 dial mounting screw through the metal dial mounting washer. Then insert the dial mounting screw/washer assembly into the spindle and tighten the dial mounting screw.

Caution: To meet the requirements of certain approval agencies, a tamper evident dial label may have been included with your lock. It is important that the next step of the installation be completed very carefully, allowing the dial label to be applied correctly on the first attempt. If the tamper evident dial label is removed after initial application, a part of the label will stay on the dial. A new label would then be required for reapplication.

22. Orient the lip of the dial to the upright position and apply the dial label to the dial. The Kaba logo should be aligned horizontally (Figure 10).

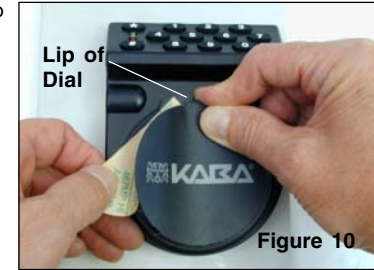

Part II: Install Lock Case Assembly

WARNING: Do not take the lock case assembly apart. The lock will not operate if the back cover has been removed.

1. Ensure that the cable lays in the cable channel as you mount the lock case assembly to the inside of the container door using the three 1/4-20 (or M6-1) screws (Torque 25-30 lbs., 2.8-3.4 N-M), allowing 1/16" (1.588mm) clearance between the lock bolt and the container locking bar. (See Figure 2 for proper clearances and positioning when installing a square nose slide bolt. See Figure 3 for proper clearances, strike types and contact points when installing a roller slide bolt.)

Note: The lock case assembly can be mounted in bolt roller up position or bolt roller down position (Figure 11) for all mounting locations. It is recommended that you use Loctite® 262 (Red) on the lock case mounting screws.

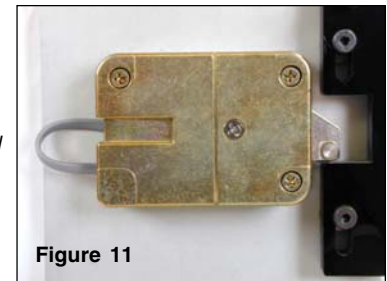

2. If your lock includes the Battery Assist option, you should now mount the battery clip inside the door near the lock and install a fresh 9 Volt Alkaline battery.

Note: To remove any excess cable or if you choose not to use the Battery Assist option, wrap and tie the battery assist cable. (Figure 12) If you do not ever plan on using the Battery Assist option, you can cut the cable next to the lock case to remove it.

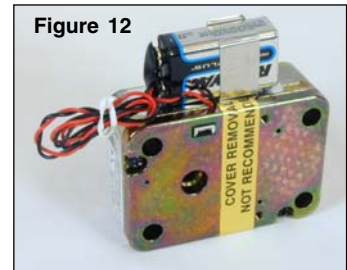

© 2005-2006 Kaba Mas Corporation. All rights reserved.
Product warranty information can be found at: www.kaba-mas.com

Kaba Mas Corporation
749 W. Short Street, Lexington, KY 40508 USA
Phone: (859) 253-4744 FAX: (859) 255-2655
Customer Service: (800) 950-4744